

# Arc Flash Protection for Medium Voltage Switchgear

## SIPROTEC 5 – Application Note

# Arc Flash Protection for Medium Voltage Switchgear

APN-041, Edition 2

## Content

1.1	Introduction	3
1.2	Sensors	3
1.2.1	Line Sensor	3
1.2.2	Point Sensor	4
1.3	Use Cases	4
1.3.1	Light Only	5
1.3.2	Light and Current	7
1.3.3	Light and Current with communication	10
1.4	Summary	12

# Arc Flash Protection for Medium Voltage Switchgear

## 1.1 Introduction

Several reasons are behind an arc appearance in medium voltage switchgear: corrosion of electrical contacts, wear and tear of components, lack of maintenance, humidity and pollution, aging of insulation materials, wrong design or installation, overvoltages, among others. The arc flash protection cares for an extremely fast trip avoiding additional damage of the assets and, even more important, for the safety of personal.

Not all the arcs are equal. The spectrum lies between 300nm and 800nm with a maximum around 500nm, but with characteristic peaks depending on the material that causes the flash.. Strong Cu-peaks are visible especially at 515 nm and 521 nm

The SIPROTEC 5 relays offer in addition to the traditional protection functions the possibility of installing optical sensors to detect arc flashes in order to bypass the time grading of the overcurrent protection in case of a real arc. In such a way faster trips are granted minimizing the damages in the switchgear and increasing the personal safety. Two operation modes are available: with light only and with light and additional current verification.

## 1.2 Sensors

### 1.2.1 Line Sensor

The line sensor detects arcs in the control cabinets of the air-insulated system part. Depending on the application, the line sensor can be, for example, laid along the busbar, or if allowed by the mechanical design of the switchgear, the line sensor can also be passed through the breaker compartment and the cable connection compartment of the feeders in addition to the busbar compartment.

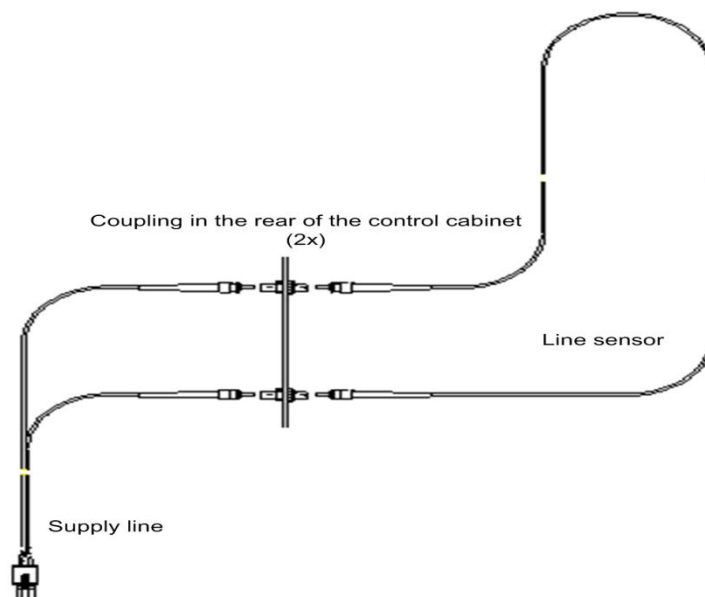

# Arc Flash Protection for Medium Voltage Switchgear

## SIPROTEC 5 Application Note

### 1.2.2 Point Sensor

The point sensor detects arcs in the control cabinets of the air-insulated system part.

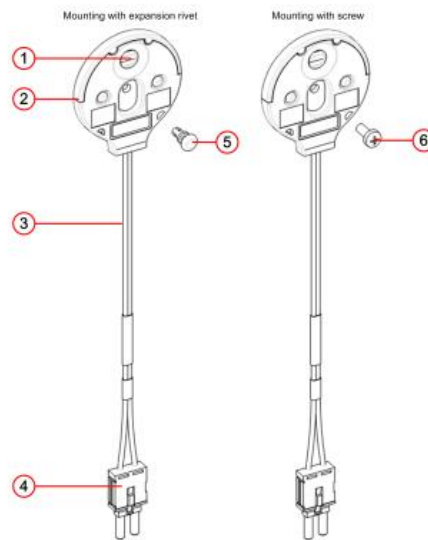

Figure 5-12 Point Sensor for the Arc-Protection Module: ARC-CD-3FO

- (1) Optically active zone
- (2) Sensor head
- (3) Supply line
- (4) Plug to the arc-protection module: ARC-CD-3FO
- (5) Expansion rivet, 4x7
- (6) Screw, M4

They can be installed in the busbar compartment, in the circuit breaker compartment and/or in the cable connection compartment.

### 1.3 Use Cases

The arc flash sensors are connected to the protection device via an ARC-CD-3FO plug in module through optical fibers. Up to 3 sensors can be connected per arc flash module.



The SIPROTEC 5 devices have in their basic module 2 slots where the plug in modules can be installed. When you use non-modular protection devices (7Sx82) a maximum of 6 sensors (3 sensors per plug-in module) can be installed. If additional sensors are required, a modular protection device can be used and extended with a CB202 communication module, which enables 3 additional slots. In total the IED can contain up to 5 slots for plug in modules and therefore can accept up to 15 sensors. Please note that under this condition, only the J port is available to perform the communication to a substation automation system and /or to other devices via IEC 61850.



# Arc Flash Protection for Medium Voltage Switchgear

## 1.3.1 Light Only

Even though the majority of arcs in medium voltage switchgear occurs in the cable connection compartment, arcs can appear in any compartment. As the current flow normally goes from the infeed through the busbar to the corresponding feeder output, only the arcs in the cable connection compartment could be cleared by its own circuit breaker. Arcs in the breaker compartment or in the busbar compartment must be cleared by the infeed circuit breaker.

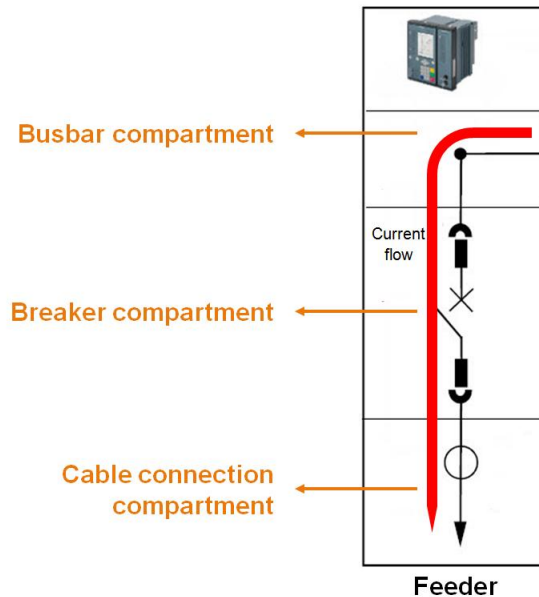

The scheme could be carried out installing one point sensor in every cable connection-compartment connected to the protection relay of the own bay. A second point sensor should be installed in the breaker compartment of each feeder, this time connected to the infeed protection relay. For the busbar compartment a line sensor can be used which must also be connected to the infeed protection relay.

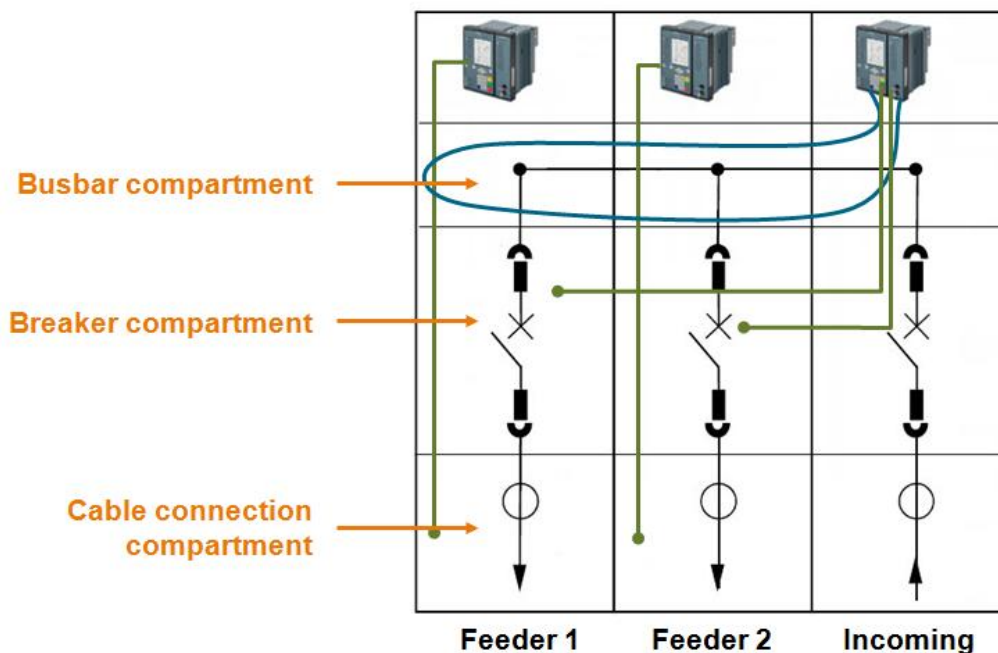

The configuration in DIGSI 5 is also quite simple. You need to create the protection relay corresponding to every feeder and also the one for the incoming bay.

# Arc Flash Protection for Medium Voltage Switchgear

## SIPROTEC 5 Application Note

### Feeders

Normally a 7SJ82 device is a good selection, although you must check whether a bigger number of inputs and outputs is required, and also if additional communication interfaces must be granted. On the other side, also different protection devices can be used in conjunction with arc protection (motor protection 7SK8, transformer protection 7UT8, among others).

In our example we will use overcurrent relays.

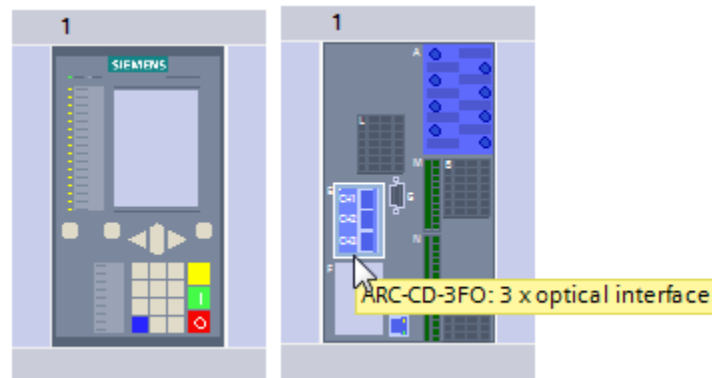

The Arc Protection is subscribed under the function group *FG Voltage-current 3ph* in the library located at the right hand of the screen in DIGSI 5. You must select the function groups and protection functions corresponding to the device type to be parameterized

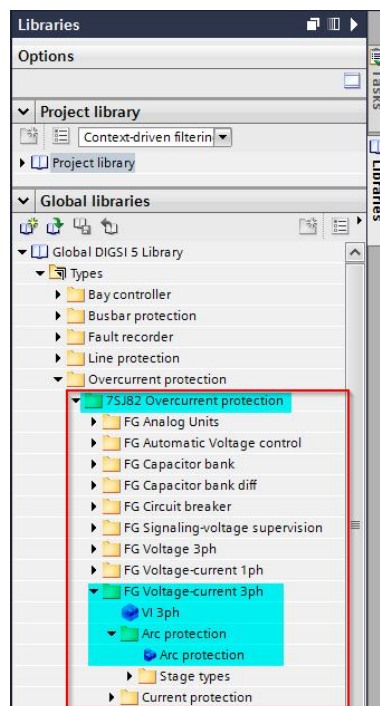

The Arc protection can have up to 17 stages. For our application here we need only one for each feeder. Below you will find the recommended settings:

IP Address	Mode	Operate & ft.rec. blocked	Channel	External trip initiation	Operating mode	Sensor
821.2151.14551.1	on					
821.2151.14551.2		no				
821.2151.14551.10			Arc module 1.channel 1			
821.2151.14551.9				no		
821.2151.14551.8					Light only	
821.2151.14551.11						Point sensor

Buttons: Add new stage, Delete stage

### Infeed

In the example shown, with only two feeders and one infeed, it is also possible to use a 7SJ82 device as infeed protection. From the arc protection side only 3 sensors are required which can be solved with only one plug-in module.

Below you will find the recommended settings.

- Line Sensor for the busbar compartment

IP Address	Mode	Operate & ft.rec. blocked	Channel	External trip initiation	Operating mode	Sensor
821.2151.14551.1	on					
821.2151.14551.2		no				
821.2151.14551.10			Arc module 1.channel 1			
821.2151.14551.9				no		
821.2151.14551.8					Light only	
821.2151.14551.11						Line sensor

Buttons: Add new stage, Delete stage

- Point Sensor for the circuit breakers (one stage per sensor)

IP Address	Mode	Operate & ft.rec. blocked	Channel	External trip initiation	Operating mode	Sensor
821.2151.14552.1	on					
821.2151.14552.2		no				
821.2151.14552.10			Arc module 1.channel 2			
821.2151.14552.9				no		
821.2151.14552.8					Light only	
821.2151.14552.11						Point sensor

Buttons: Add new stage, Delete stage

### 1.3.2 Light and Current

The additional current criterion ensures that the light detection occurs actually as a result of an arc fault and not due to external harmless light. Therefore it is strongly recommended to use the current criterion to avoid any overfunction due to ambient light. Depending on the physical location of the current transformers in the cable connection-compartment, a similar installation scheme as the shown in the chapter *1.3.1 Light only* could be used. However, as it could happen that the location of the CTs allows the possibility of an arc flash in the compartment without the possibility to measure the current, it is highly recommended to use the current measurement in the infeed bay. Therefore, all sensors must be connected to the infeed protection relay.

# Arc Flash Protection for Medium Voltage Switchgear

## SIPROTEC 5 Application Note

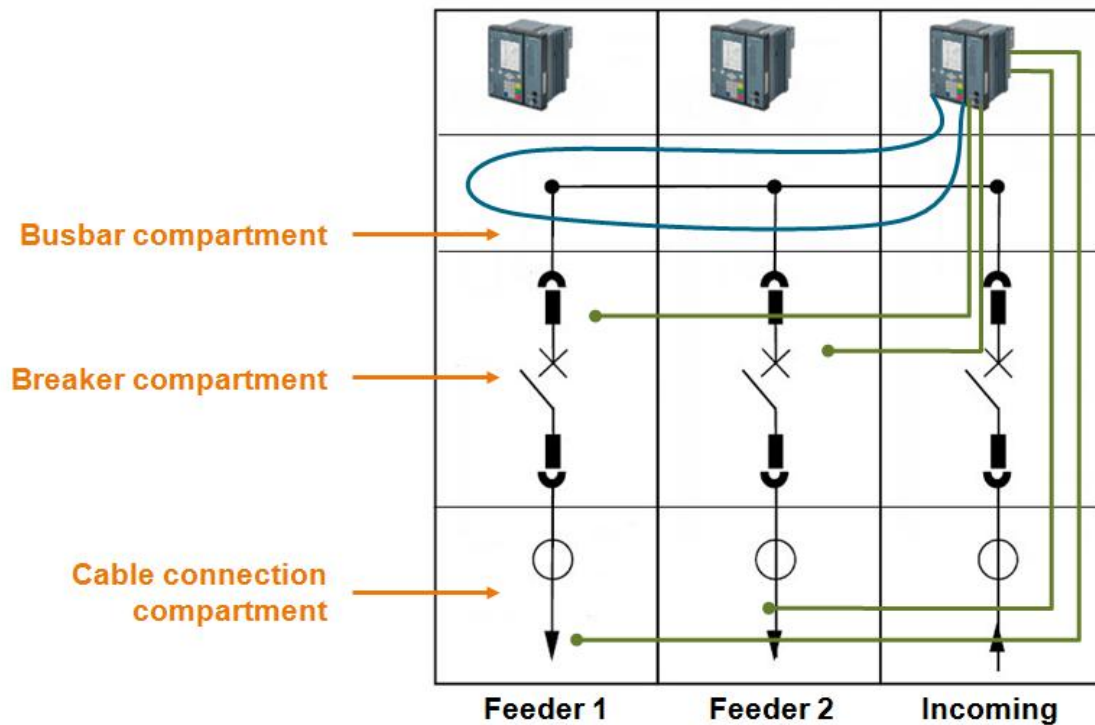

In the example shown above, with only two feeders and one infeed, it is still possible to use a 7SJ82 device as infeed protection; from the arc protection side only 5 sensors are required which can be solved with two plug-in modules. The communication to a substation automation system will be done by using the J-Port (electrical) with IEC61850 MMS and GOOSE. If the communication shall be optical, additional bays are to be connected or a different protocol is needed, you can select a 7SJ85 relay with a CB202 expansion module.

You must also keep in mind, that any combination of line and points sensors is allowed. The use of line sensors is only limited by the mechanical design of the switchgear.

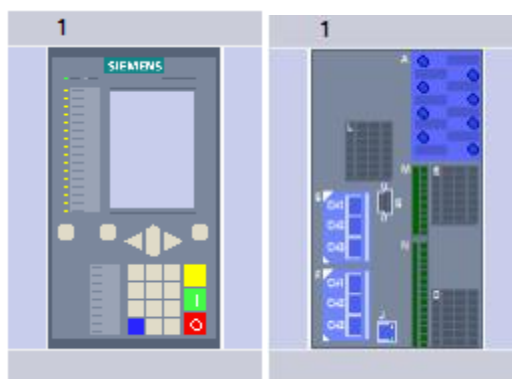



# Arc Flash Protection for Medium Voltage Switchgear

## SIPROTEC 5 Application Note

Below you will find the recommended settings.

- Current Settings

General	
821.2151.2311.3	Threshold I>: A
821.2151.2311.4	Threshold 3I0>: A
<input type="button" value="Add new stage"/> <input type="button" value="Delete stage"/>	

The thresholds for I> and 3I0> must be adjusted taking into account the following recommendations:

Parameter: Threshold I>

Use the parameter Threshold I> to define the trigger threshold of the phase currents. Set the Threshold I> of the function Arc protection in such a manner that the RMS value of the inrush current does not exceed the Threshold I> when activating the local circuit breaker.

Parameter: Threshold 3I0>

Use the parameter Threshold 3I0> to determine the tripping threshold for the zero-sequence current. Set the Threshold 3I0> of the function Arc protection in such a manner that the RMS value of the inrush current does not exceed the Threshold 3I0> when activating the local circuit breaker.

For more information about how to calculate the setting value, refer to 6.5.4.2 Application and Setting Notes of the Manual SIPROTEC 5, Overcurrent Protection, Manual (C53000-G5040-C017-7, Edition 07.2016)

- Line Sensor for the busbar compartment

Stage 1	
821.2151.14551.1	Mode: on
821.2151.14551.2	Operate & ft.rec. blocked: no
821.2151.14551.10	Channel: Arc module 1.channel 1
821.2151.14551.9	External trip initiation: no
821.2151.14551.8	Operating mode: Current and light
821.2151.14551.11	Sensor: Line sensor
<input type="button" value="Add new stage"/> <input type="button" value="Delete stage"/>	

- Point Sensor for the circuit breakers and cable-connection compartments (one stage per sensor)

Stage 2	
821.2151.14552.1	Mode: on
821.2151.14552.2	Operate & ft.rec. blocked: no
821.2151.14552.10	Channel: Arc module 1.channel 2
821.2151.14552.9	External trip initiation: no
821.2151.14552.8	Operating mode: Current and light
821.2151.14552.11	Sensor: Point sensor
<input type="button" value="Add new stage"/> <input type="button" value="Delete stage"/>	

# Arc Flash Protection for Medium Voltage Switchgear

## SIPROTEC 5 Application Note

### 1.3.3 Light and Current with communication

It is also possible to build a light –current scheme in switchgear with a high number of bays where more than 15 sensors could be required. With that aim, the capability of initiating the arc protection via an external signal is to be used. Every relay receives the sensors installed in their own compartments (normally 3: busbar, circuit breaker and cable-connection) and sends the information to the Infeed relay in case an arc flash is detected. The information transmission can be done via GOOSE, copper cable from binary outputs from the feeders to binary inputs of the infeed or even via protection data interface. Those signals are used to initiate the arc protection in the infeed relay which will measure the current to decide whether a trip must be released. The infeed can also send the information of its own arcs to an upstream relay.

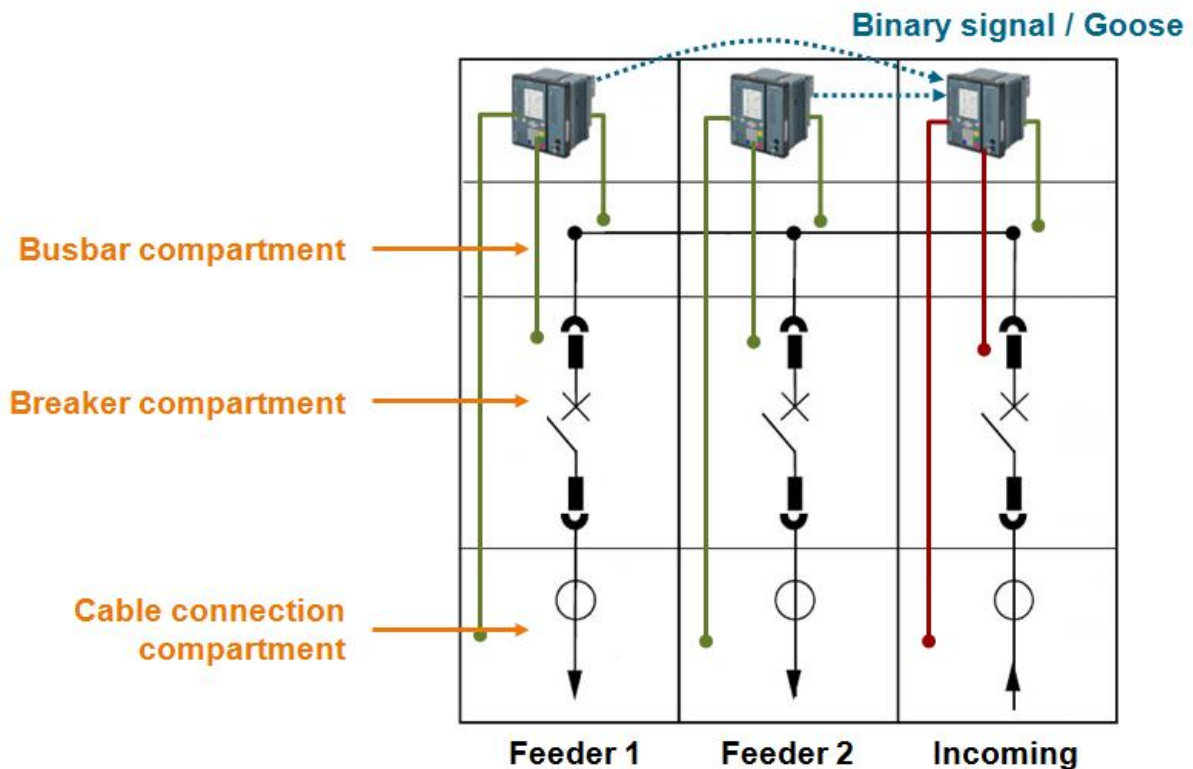

Feeders

The arc protection function needs three stages (one stage per sensor).

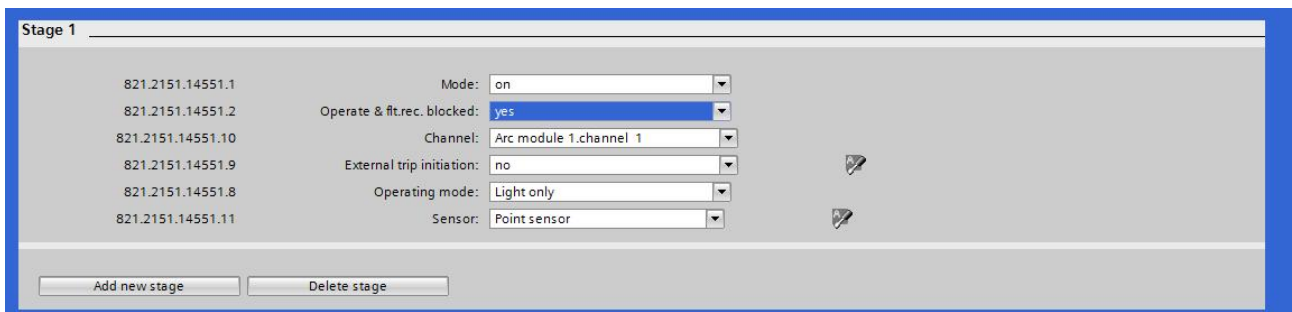

# Arc Flash Protection for Medium Voltage Switchgear

## SIPROTEC 5 Application Note

### Infeed

There are two ways to start the arc flash protection stage in the Infeed device as a result of an arc flash detection in one of the feeders:

- Using n different stages, one per sensor
- Using a CFC to evaluate the signals coming from the different feeders and release a unique arc flash stage

In this example we use the option a.

- Point Sensor for the busbar, circuit breakers and cable-connection compartments of every feeder (one stage per sensor)

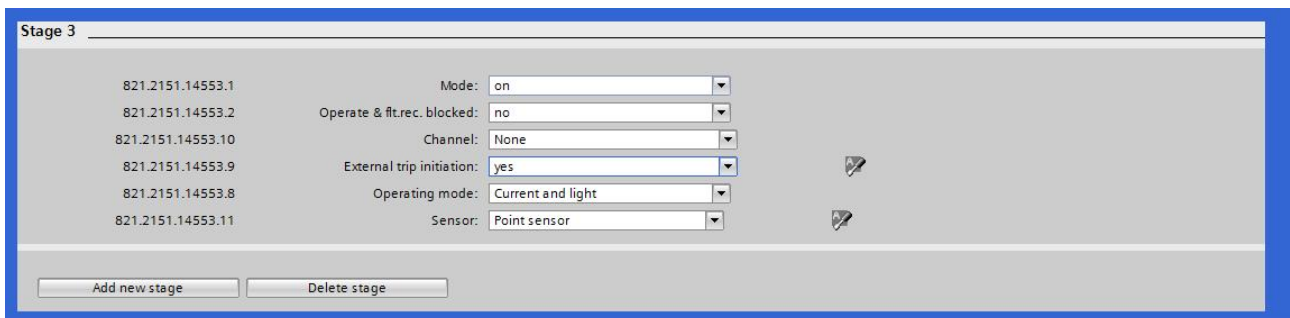

Stage 3 configuration interface showing settings for five feeders. Each feeder has a unique ID and is configured with a 'Point sensor' and 'Current and light' operating mode. The 'External trip initiation' is set to 'yes' for all feeders. The 'Channel' is set to 'None' for all feeders. The 'Mode' is set to 'on' and 'Operate & ft.rec. blocked' is set to 'no' for all feeders. There are 'Add new stage' and 'Delete stage' buttons at the bottom.

ID	Mode	Operate & ft.rec. blocked	Channel	External trip initiation	Operating mode	Sensor
821.2151.14553.1	on	no	None	yes	Current and light	Point sensor
821.2151.14553.2	on	no	None	yes	Current and light	Point sensor
821.2151.14553.10	on	no	None	yes	Current and light	Point sensor
821.2151.14553.9	on	no	None	yes	Current and light	Point sensor
821.2151.14553.8	on	no	None	yes	Current and light	Point sensor
821.2151.14553.11	on	no	None	yes	Current and light	Point sensor

- Point Sensor for the busbar compartment of the infeed

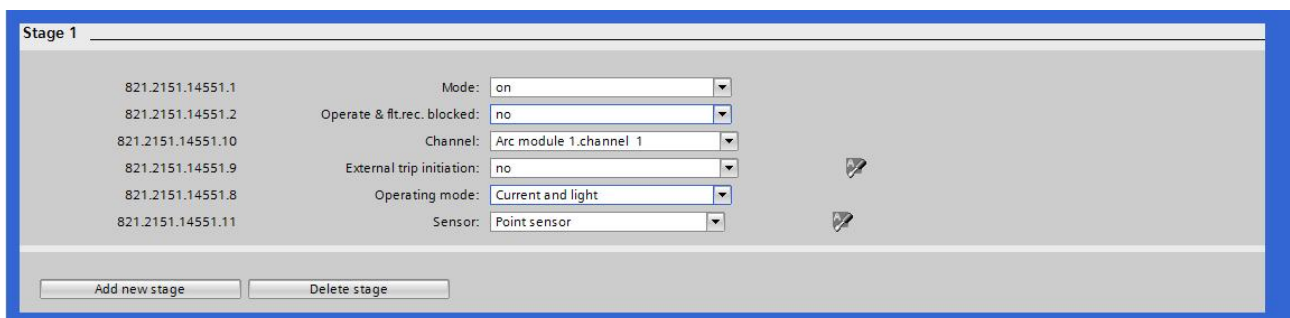

Stage 1 configuration interface showing settings for five feeders. Each feeder has a unique ID and is configured with a 'Point sensor' and 'Current and light' operating mode. The 'External trip initiation' is set to 'no' for all feeders. The 'Channel' is set to 'Arc module 1.channel 1' for all feeders. The 'Mode' is set to 'on' and 'Operate & ft.rec. blocked' is set to 'no' for all feeders. There are 'Add new stage' and 'Delete stage' buttons at the bottom.

ID	Mode	Operate & ft.rec. blocked	Channel	External trip initiation	Operating mode	Sensor
821.2151.14551.1	on	no	Arc module 1.channel 1	no	Current and light	Point sensor
821.2151.14551.2	on	no	Arc module 1.channel 1	no	Current and light	Point sensor
821.2151.14551.10	on	no	Arc module 1.channel 1	no	Current and light	Point sensor
821.2151.14551.9	on	no	Arc module 1.channel 1	no	Current and light	Point sensor
821.2151.14551.8	on	no	Arc module 1.channel 1	no	Current and light	Point sensor
821.2151.14551.11	on	no	Arc module 1.channel 1	no	Current and light	Point sensor

- Point Sensor for the circuit breakers and cable-connection compartments of the infeed (one stage per sensor)

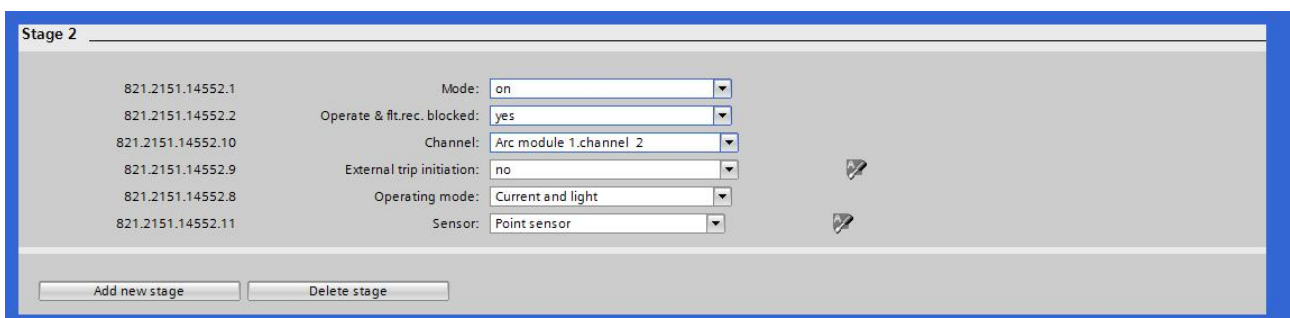

Stage 2 configuration interface showing settings for five feeders. Each feeder has a unique ID and is configured with a 'Point sensor' and 'Current and light' operating mode. The 'External trip initiation' is set to 'no' for all feeders. The 'Channel' is set to 'Arc module 1.channel 2' for all feeders. The 'Mode' is set to 'on' and 'Operate & ft.rec. blocked' is set to 'yes' for all feeders. There are 'Add new stage' and 'Delete stage' buttons at the bottom.

ID	Mode	Operate & ft.rec. blocked	Channel	External trip initiation	Operating mode	Sensor
821.2151.14552.1	on	yes	Arc module 1.channel 2	no	Current and light	Point sensor
821.2151.14552.2	on	yes	Arc module 1.channel 2	no	Current and light	Point sensor
821.2151.14552.10	on	yes	Arc module 1.channel 2	no	Current and light	Point sensor
821.2151.14552.9	on	yes	Arc module 1.channel 2	no	Current and light	Point sensor
821.2151.14552.8	on	yes	Arc module 1.channel 2	no	Current and light	Point sensor
821.2151.14552.11	on	yes	Arc module 1.channel 2	no	Current and light	Point sensor

# Arc Flash Protection for Medium Voltage Switchgear

## SIPROTEC 5 Application Note

---

### 1.4 Summary

The modularity of the SIPROTEC 5 devices is playing an important role to protect medium voltage switchgear to the best selectivity and availability at a convenient cost –benefit position.

Depending on the number of bays in your switchgear and its mechanical design, a combination of line and point sensor as well as physical and communication connectivity can be used to design an efficient arc flash protection scheme. By using the arc flash protection the security of the personal and the assets can be improved as the time grading of the overcurrent protection can be by-passed if an arc is detected; and all this without significantly increasing the investment.

# Arc Flash Protection for Medium Voltage Switchgear

SIPROTEC 5 Application Note

---



Published by and copyright © 2018:

Siemens AG  
Energy Management Division  
Humboldtstr. 59  
90459 Nuremberg, Germany  
[www.siemens.com/siprotec](http://www.siemens.com/siprotec)

For more information, please contact your Siemens  
Partner or our Customer Support Center.

Phone: +49 180 524 70 00

Fax: +49 180 524 24 71

(Charges depending on the provider)

Email: [support.energy@siemens.com](mailto:support.energy@siemens.com)

Printed on elementary chlorine-free bleached paper.  
All rights reserved.

Trademarks mentioned in this document are the  
property of Siemens AG, its affiliates, or their respective  
owners.

Subject to change without prior notice.

The information in this document contains general  
descriptions of the technical options available, which  
may not apply in all cases. The required technical  
options should therefore be specified in the contract.

For all products using security features of OpenSSL  
the following shall apply:

This product includes software developed by the  
OpenSSL Project for use in the OpenSSL Toolkit  
([www.openssl.org](http://www.openssl.org)).

This product includes cryptographic software written  
by Eric Young ([eay@cryptsoft.com](mailto:eay@cryptsoft.com)).