

SIEMENS



SIPROTEC 5 Compact

Change setting groups via CFC

APN – C.020

SIPROTEC 5 Compact Application

Change setting groups via CFC

SIPROTEC 5 Compact Application

Change setting groups via CFC

APN-C.020, Edition 1

Contents

1	Introduction.....	3
2	The application	3
2.1	Activation of setting group change via CFC.....	3
2.2	Handling of setting groups.....	3
2.3	The selection logic.....	5
3	Conclusion.....	6

1 Introduction

In some applications it is beneficial to have more than one Setting Group in the device. Based on primary system conditions the appropriate setting group is then selected. The selection of the setting group may be implemented with binary inputs or control inputs via interface. In some cases, the selection will be based on conditions derived from a user defined logic implemented with CFC in the device. This application note will show how the CFC logic interfaces with the Setting Group selection.

To concentrate on the essential, we change, as an example, between 2 setting groups via the function key No 8.

2 The application

2.1 Activation of setting group change via CFC

SIPROTEC 5 supports up to 8 setting groups. To apply more than one setting group the desired number of setting groups must be entered under Settings -> Device settings as shown in Figure 1 below:

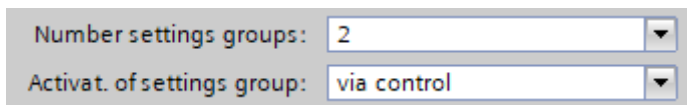

Number settings groups: 2

Activat. of settings group: via control

Figure 1: Enter the number of desired setting groups

The "Active setting group" parameter must be set to "via control" if the selection is done via CFC. If not, the CFC described below will not change the setting groups as desired.

2.2 Handling of setting groups

A practical workflow to configure all setting groups could be the following:

1. Make all the settings for one setting group.
2. Copy this setting group to the other setting group(s).
3. Adjust the specific settings in each setting group.

In our example we want to set different values for the pick-up threshold of the first overcurrent protection stage "Definite-T1". Entering the settings editor, we must ensure, that the "Values for change" selection is set to "settings group 1" (see Figure 2).

SIPROTEC 5 Compact Application

Change setting groups via CFC

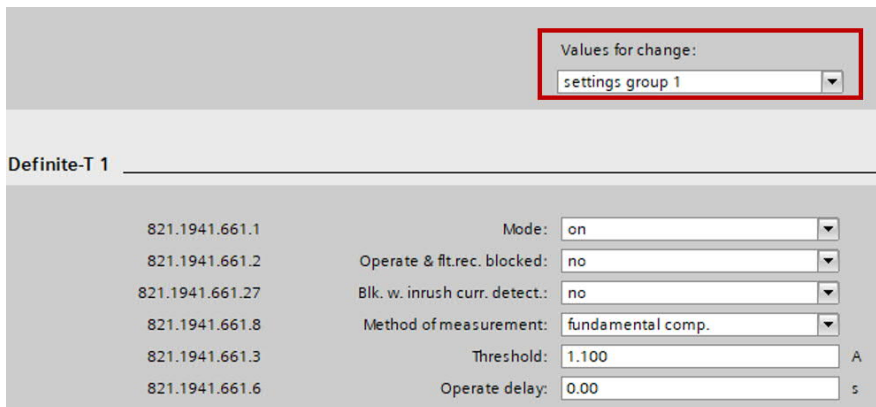

Figure 2: Selection of the setting group to be modified

In our example the settings for threshold and operate delay were modified.

In a second step we can copy setting group 1 to setting group 2. The setting group selection and the copy button can be found under Settings -> Device settings:

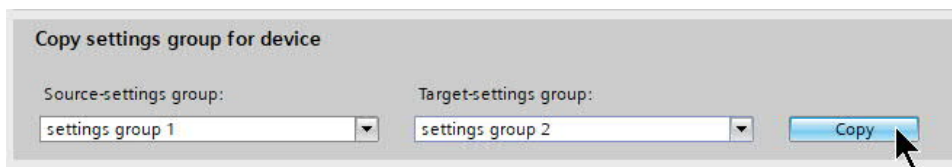

Figure 3: Copy setting group 1 to setting group 2

Finally, setting group 2 settings are adjusted. Therefore, we select "settings group 2" for the "Values for change" window. Additionally, we can compare setting group 2 with setting group 1 by selecting "settings group 1" in the window "Values for comparison" (Figure 4) The differences are marked with a "blue circle and yellow triangle" symbol.

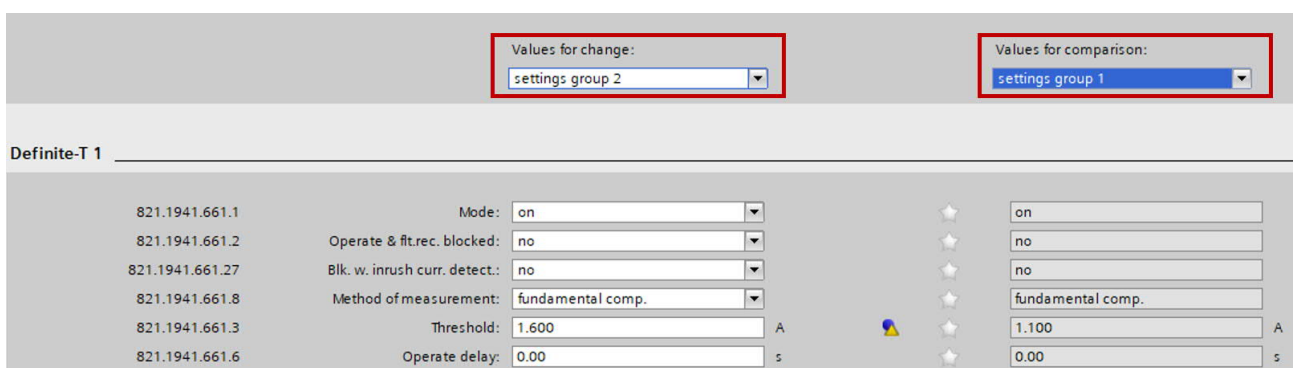

Figure 4: values for change and values for comparison

We see that the pick-up threshold of "Definite-T1" between the two parameter groups is different.

2.3 The selection logic

Pressing the function key 8 should toggle the active setting group.

In a first step we create a user defined SPS signal called "FK 8" for the state of FK8 in the FB "General" and assign it to the FK 8 with "T" like toggle. This means, that the value of the SPS signal "FK 8" changes its value from 0 to 1 and back to 0 each time, the function key 8 is pressed.

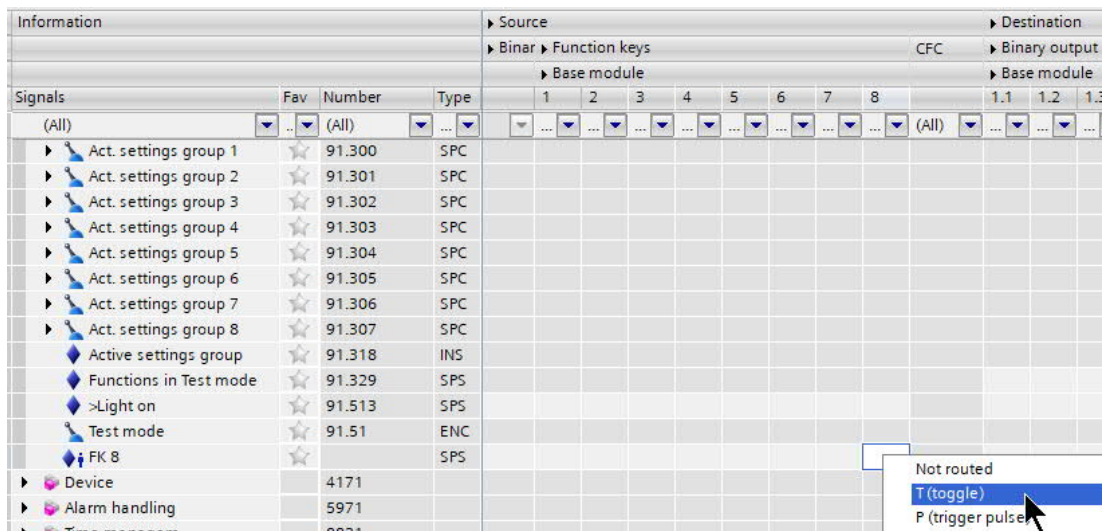

Figure 5: Assignment of FK 8 to the user defined signal "FK 8"

In Figure 5 we see also the so called controllables "Act. settings group 1" to "Act. settings group 8" which we use in the CFC to activate the respective settings group.

The final logic consists of 2 CFC control elements "SPC_OUT" which are used to switch the controllables "General.Act.settings group 1" and "General.Act.settings group 2". The controllables to be changed are not at the output of the CFC control blocks but like parameters at the input "ID".

For the trigger of the SPC_OUT blocks we use the signal "FK 8". With the Input "EDGE" set to 1, the trigger reacts on both, a rising and a falling edge of the signal at the Input "TRIG".

With the signal "FK8" which toggles from 0 to 1 and back to 0 each time the function key 8 is pressed we additionally define the VAL input of the block SPC_OUT. If VAL = 0, the setting group is deselected, for VAL=1 the setting group is selected. With the negation of VAL for the first setting group we select this setting group when the signal "FK 8" is 0 and deselect it, when "FK 8" is 1. The negation can be either done with a dedicated negator element (NEG) or by right mouse clicking on the connection line and selecting the Negate option as shown in Figure 6.

It is important that only one setting group is selected at a time, otherwise the last selection according to the run sequence "wins". This is given by the before described negation and therefore cross wise values at the "VAL" inputs of both SPC_OUT modules.

SIPROTEC 5 Compact Application

Change setting groups via CFC

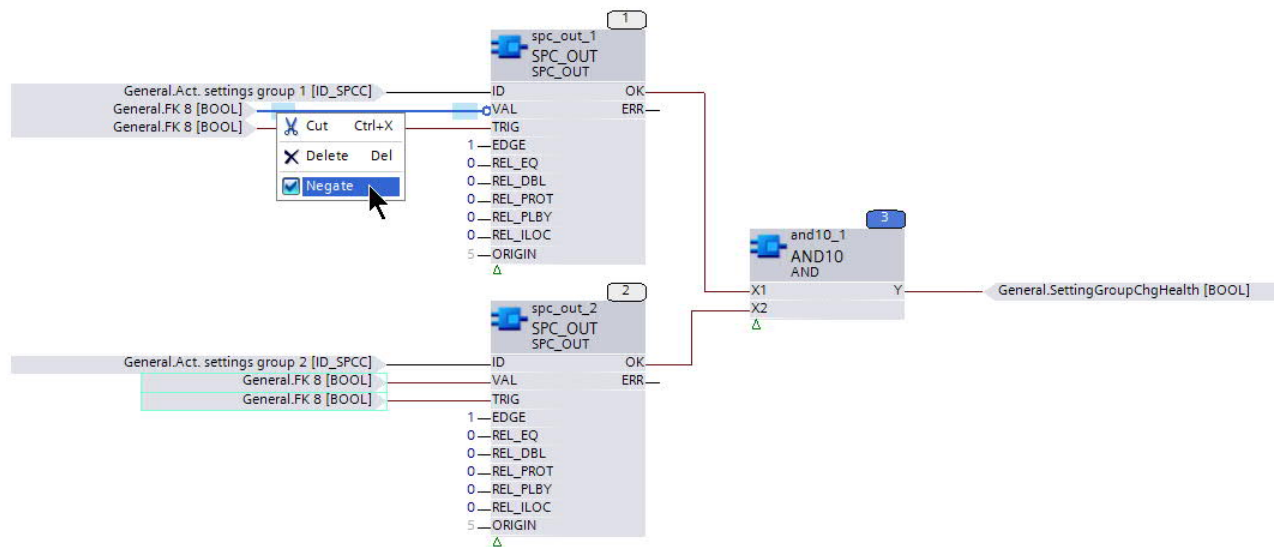

Figure 6: The CFC logic for the setting group selection

With the output OK of the SPC_OUT modules we get information if the commands are executed correctly. “AND”ing both signals to a second user defined signal called “SettingGroupChgHealth” we have a signal which helps to monitor the correct working of the selection logic.

A detailed description of the CFC logic elements can be found in the DIGSI 5 manual which is provided on our home page.

Finally, we can use the controllable states to indicate the active setting group, which we find in the information routing matrix and which we can assign for example to LEDs (Figure 7Figure 7).

Information				Sourr ▶ Destination			
				▶ Binar ▶ LEDs			
				▶ Base modu			
Signals	Fav	Number	Type			1.1	1.2
(All)	..	(All)	...	▼	▼	...	▼
▼ Act. settings group 1	☆	91.300	SPC			*	
♦ off			SPS				
♦ on			SPS			U	
▼ Act. settings group 2	☆	91.301	SPC				*
♦ off			SPS				
♦ on			SPS				U

Figure 7: Assignment of active setting groups to LEDs

3 Conclusion

Setting groups can be changed depending on e.g., operating conditions using the CFC logic editor with the CFC element SPC_OUT and the controllables “Act.settings group x”. Special care should be taken that the CFC does not select multiple setting groups at the same time. The CFC logic can be also simulated being online with a device or the Digital Twin application. This simulation is described in a separate application note.

Published by
Siemens AG 2021

Smart Infrastructure
Digital Grid
Automation Products
Humboldtstr. 59
90459 Nuremberg, Germany
www.siemens.com/siprotec

Our Customer Support Center
provides a 24-hour service.
Siemens AG
Smart Infrastructure – Digital
Grid Customer Support Center
E-Mail:
energy.automation@siemens.com
m

For all products using security features of
OpenSSL the following shall apply:

This product includes software developed by
the OpenSSL Project for use in the OpenSSL
Toolkit. (<http://www.openssl.org>)

This product includes cryptographic software
written by Eric Young (eay@cryptsoft.com)

This product includes software written
by Tim Hudson (tjh@cryptsoft.com)

This product includes software developed
by Bodo Moeller.