

SIEMENS



www.siemens.com/protection

SIPROTEC 5 Application

SIP5-APN-026:

Sync Check with Voltage selection and VTs with different ratio

SIPROTEC 5 Application

Sync Check with Voltage selection and VTs with different ratio

SIPROTEC 5 - Application: Sync Check with Voltage selection and VTs with different ratio

Contents:

1	Sync Check with Voltage selection and VTs with different ratio	3
1.1	Introduction	3
1.2	Application	4
1.3	DIGSI Settings	5
1.4	Tests	5

1 Sync Check with Voltage selection and VTs with different ratio

1.1 Introduction

The VT ratio of all VTs “connected” to either Vsyn1 or Vsyn2 must be the identical. If different VT values are set DIGSI will show an inconsistency and the configuration cannot be loaded into the device. (The VT at Vsyn1 may be different from the VT at Vsyn2)

In this description a “work around” is shown for the case when different VT ratios are applied. The selection logic is covered in the separate application note SIP5-APN-004.

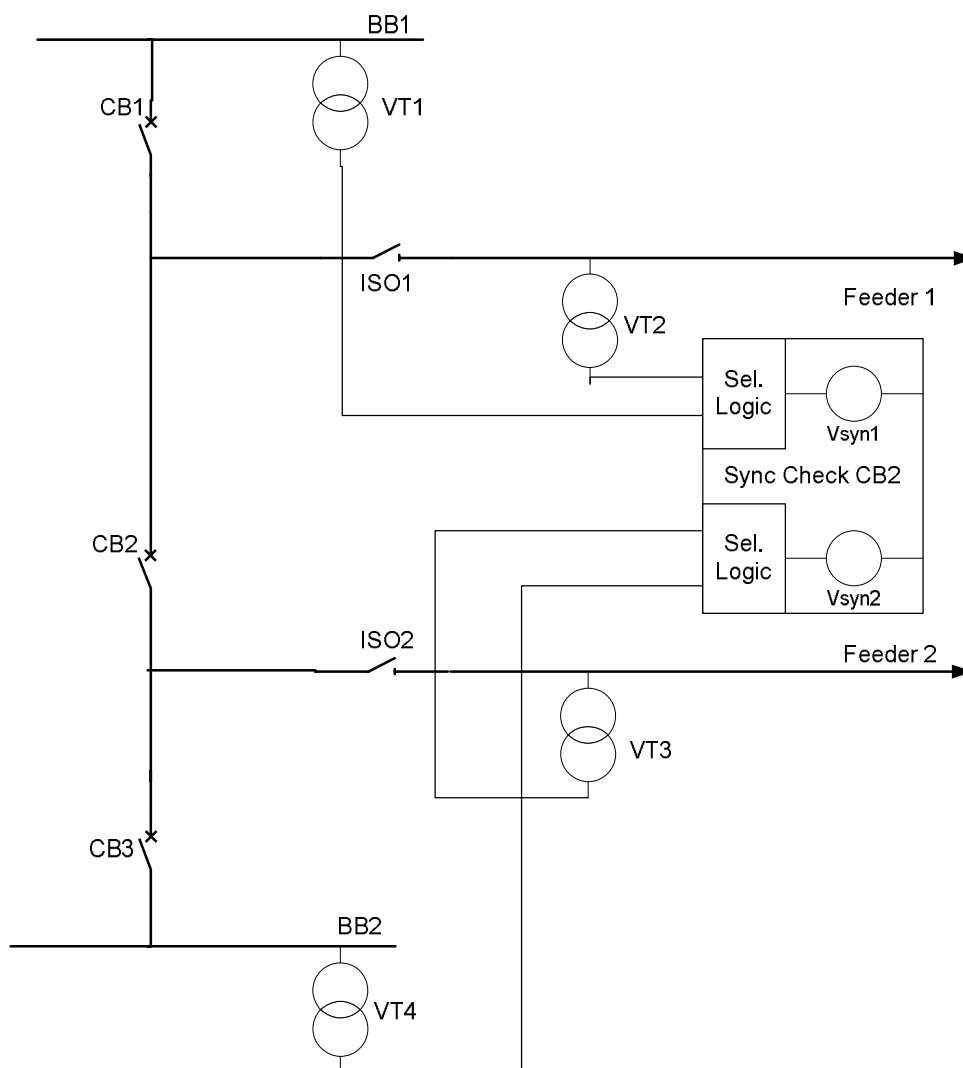

Figure 1: Single line showing VTs for sync check.

VT ratios for the example shown in Figure 1:

VT	Connection	Ratio
VT1	Vsyn1	230 kV / 110 V
VT2	Vsyn1	220 kV / 110 V
VT3	Vsyn2	220 kV / 110 V
VT4	Vsyn2	220 kV / 110 V

Table 1: VT ratio from plant data

SIPROTEC 5 Application

Sync Check with Voltage selection and VTs with different ratio

This presents two problems:

1. The primary rated voltage of VT3 and VT4 are not the same as VT1 which is used as reference in this example. Under this condition the sync check expects a power transformer with corresponding ratio between these measuring points. The primary rated voltage must be set the same by applying the work around covered by Note 1 below.
2. The ratio of VT1 and VT2 are not the same although they are both assigned to Vsync1. This is not permitted. The ratios must be set the same by applying the work around covered by Note 2 below.

1.2 Application

For the Sync Check in this example there are two requirements for the VT ratio:

1. The primary voltage must be the same for all VT used for sync check. If the primary voltage is different the sync check considers a transformer with corresponding ratio difference between the measuring points.
2. The primary and secondary voltage of VTs connected to one side (either Vsyn1 or Vsyn2) must be identical.

To illustrate the two methods that can be adopted when the VTs do not comply with the two requirements above the VT settings will be applied as follows (VT1 is chosen as reference):

VT parameters			Settings applied		
VT	Connection	Ratio	Set Rated primary voltage	Set Rated secondary voltage	Set Magnitude correction
VT1	Vsyn1	230 kV / 110 V	230 kV	110 V	1
VT2	Vsyn1	220 kV / 110 V	230 kV	110 V	0.956 (note 2)
VT3	Vsyn2	220 kV / 110 V	230 kV	115 V (note 1)	1
VT4	Vsyn2	220 kV / 110 V	230 kV	115 V (note 1)	1

Table 2: Derived VT ratio settings

Note 1 – Adapted VT is not on same side as reference CT:

Here the set VT primary rated voltage must be adapted to be the same as that of the reference VT which is VT1 in this example. The set primary voltage now deviates from the actual VT rating. The secondary rated voltage must be adapted so that the ratio remains correct:

$$\text{Set Rated secondary voltage} = \frac{\text{Set rated primary voltage}}{\text{VT primary voltage}} \cdot \text{Vt secondary voltage}$$

$$\text{Set Rated secondary voltage} = \frac{230\text{kV}}{220\text{kV}} \cdot 110\text{V}$$

$$\text{Set Rated secondary voltage} = 115\text{V}$$

Note 2 – Adapted VT is connected to the same side as reference VT:

Here the set VT primary and/or secondary rated voltage must be adapted to be the same as that of the reference VT. The set ratio now deviates from the real ratio. This ratio deviation is compensated with the Magnitude Correction setting:

$$\text{Set Magnitude correction} = \frac{\text{Set rated secondary voltage}}{\text{Set rated primary voltage}} \cdot \frac{\text{VT primary voltage}}{\text{VT secondary voltage}}$$

SIPROTEC 5 Application

Sync Check with Voltage selection and VTs with different ratio

$$\text{Set Magnitude correction} = \frac{220\text{kV}}{110\text{V}} \cdot \frac{110\text{V}}{230\text{kV}}$$

$$\text{Set Magnitude correction} = 0.956$$

1.3 DIGSI Settings

For all VTs the settings calculated above and shown in Table2 must be applied with DIGSI as shown for VT2 in screen shot below.

The screenshot displays the configuration interface for Voltage Transformers (VTs) in the DIGSI software. It is divided into two main sections: 'VT 3-phase' and 'VT 1'.

VT 3-phase settings:

- 11.941.8911.101: Rated primary voltage: 230.00 kV
- 11.941.8911.102: Rated secondary voltage: 110 V
- 11.941.8911.103: Matching ratio Vph / VN: 1.73
- 11.941.8911.104: VT connection: 3 ph-to-gnd volt. + VN
- 11.941.8911.106: Inverted phases: none
- 11.941.8911.111: Tracking: active
- 11.941.8911.130: Measuring-point ID: 2

Buttons for 'Add new stage' and 'Delete stage' are visible below the VT 3-phase settings.

VT 1 settings:

- 11.941.3811.103: Magnitude correction: 0.956
- 11.941.3811.108: Phase: VA

Figure 2: Settings of VT ratio and Magnitude correction (shown are VT2 settings)

1.4 Tests

During final commissioning the above VT ratio settings must be checked by monitoring the measurements in the device. Prior tests with secondary injection are recommended:

VT	Assumed Primary Voltage (Ph-Ph)	Injected secondary voltage (Ph-G)	Measured values	
			Primary (Ph-Ph)	Secondary (Ph-Ph)
VT1 230k/110	220 kV	60.75 V	220 kV	105.2 V
VT2 220k/110	220 kV	63.51 V	220 kV	105.2 V
VT3 220k/110	220 kV	63.51 V	220 kV	110 V
VT4 220k/110	220 kV	63.51 V	220 kV	110 V

Table 3: Test values for secondary injection

SIPROTEC 5 Application

Sync Check with Voltage selection and VTs with different ratio

While injecting the secondary voltage, the measured values can be checked:

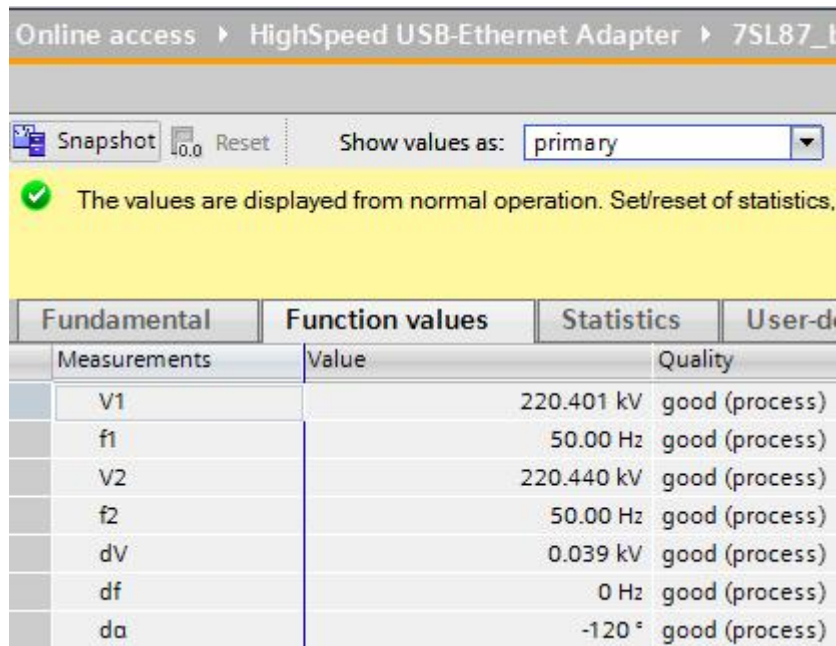

Fundamental	Function values	Statistics	User-d
Measurements	Value		Quality
V1	220.401 kV		good (process)
f1	50.00 Hz		good (process)
V2	220.440 kV		good (process)
f2	50.00 Hz		good (process)
dV	0.039 kV		good (process)
df	0 Hz		good (process)
da	-120 °		good (process)

Figure 3: Screen shot primary measured values (da= 120° is due to test condition, normally 0°)

As shown, the primary voltage is 220 kV at Vsyn1 (V1) and Vsyn2 (V2). This must be checked for all VTs by changing the selection with "V sync select."

The secondary voltage should also be checked to be sure that all settings are correct:

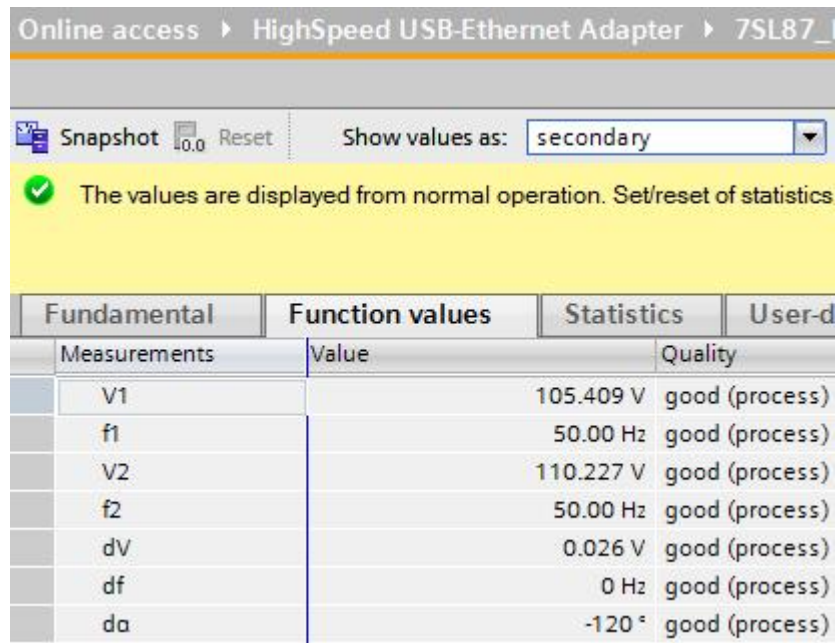

Fundamental	Function values	Statistics	User-d
Measurements	Value		Quality
V1	105.409 V		good (process)
f1	50.00 Hz		good (process)
V2	110.227 V		good (process)
f2	50.00 Hz		good (process)
dV	0.026 V		good (process)
df	0 Hz		good (process)
da	-120 °		good (process)

Figure 4: Screen shot secondary measured values (V1 measured with VT2) (da= 120° is due to test condition, normally 0°)

SIPROTEC 5 Application

Sync Check with Voltage selection and VTs with different ratio

In the screen shot above, the VT connected to Vsyn1 (V1) is VT2. The measured secondary voltage is 105 V due to the magnitude correction. This can be calculated as follows:

$$\text{Measured secondary voltage (Ph - Ph)} = \text{Injected Voltage (Ph - G)} \cdot \sqrt{3} \cdot \text{Mag. Corr}$$

$$\text{Measured secondary voltage (Ph - Ph)} = 63.51 \cdot \sqrt{3} \cdot 0.956$$

$$\text{Measured secondary voltage (Ph - Ph)} = 102.5$$

Note that the delta voltage (dV) is always zero (with primary and secondary measured values) when the primary voltage is the same on both sides.

Published by and copyright © 2013:

Siemens AG

Infrastructure & Cities Sector

Smart Grid Division

Humboldtstr. 59

90459 Nuremberg, Germany

Siemens AG

Infrastructure & Cities Sector

Smart Grid Division

Energy Automation

Humboldtstr. 59

90459 Nuremberg, Germany

www.siemens.com/protection

Printed on elementary chlorine-free bleached paper.

All rights reserved.

If not stated otherwise on the individual pages of this catalog, we reserve the right to include modifications, especially regarding the stated values, dimensions and weights. Drawings are not binding.

All product designations used are trademarks or product names of Siemens AG or other suppliers.

If not stated otherwise, all dimensions in this catalog are given in mm.

Subject to change without prior notice.

The information in this document contains general descriptions of the technical options available, which may not apply in all cases. The required technical options should therefore be specified in the contract.

For more information, please contact
our Customer Support Center.

Tel.: +49 180 524 8437

Fax: +49 180 524 24 71

(Charges depending on provider)

E-mail: support.ic@siemens.com

Application note: SIP5-APN-026